

Fonte, Fonte Totem



IT **ATTENZIONE:** Nel caso di inosservanza delle note tecniche, l'azienda declina ogni responsabilità per mal funzionamento degli articoli, danni a cose e/o persone. Rexa declina ogni responsabilità in caso di errata o non corretta installazione dei propri prodotti e dei prodotti da lei commercializzati e in caso di utilizzo improprio degli stessi. L'azienda si riserva di cambiare schede tecniche e caratteristiche di funzionamento degli articoli in ogni momento e senza necessità di preavviso.

EN **ATTENTION:** If the installation instructions are not respected, Rexa Design will not be held responsible for any abnormal functioning or damage. Rexa Design S.r.l. declines any responsibility for the wrong or not correct installation of products made or commercialized by it self and also in case of improper use of them. The company reserves the right to change any technical specifications / dimension and / or operating characteristics of the products at any time and without giving notice.

REXA

Fonte, Fonte Totem

* Altezza consigliata / Suggested height

● Scarico / Drain

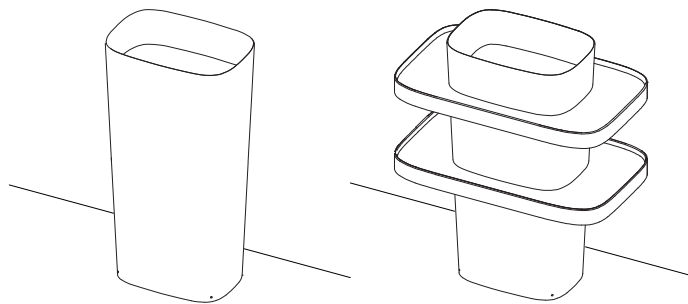

- Per collegamento piletta consultare il manuale nell'imballo dedicato / For connecting the drain refer to the manual in the dedicated packaging

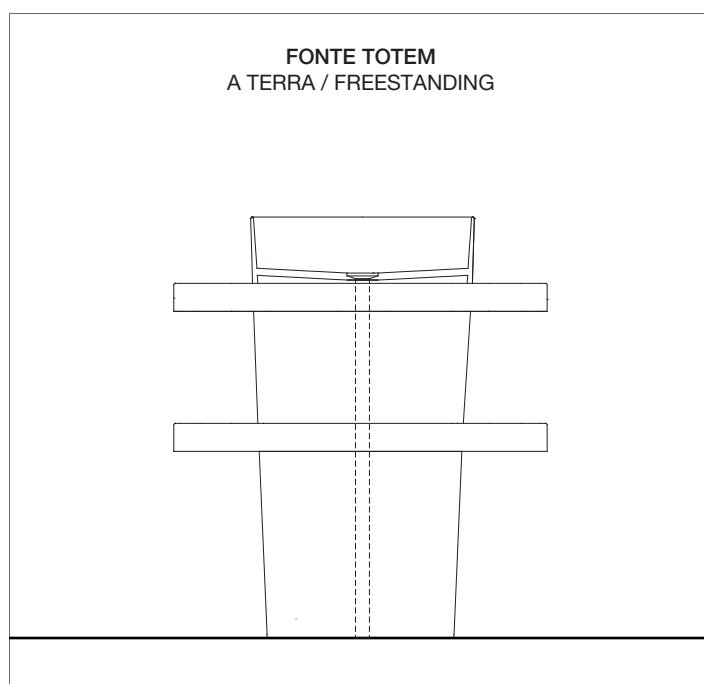
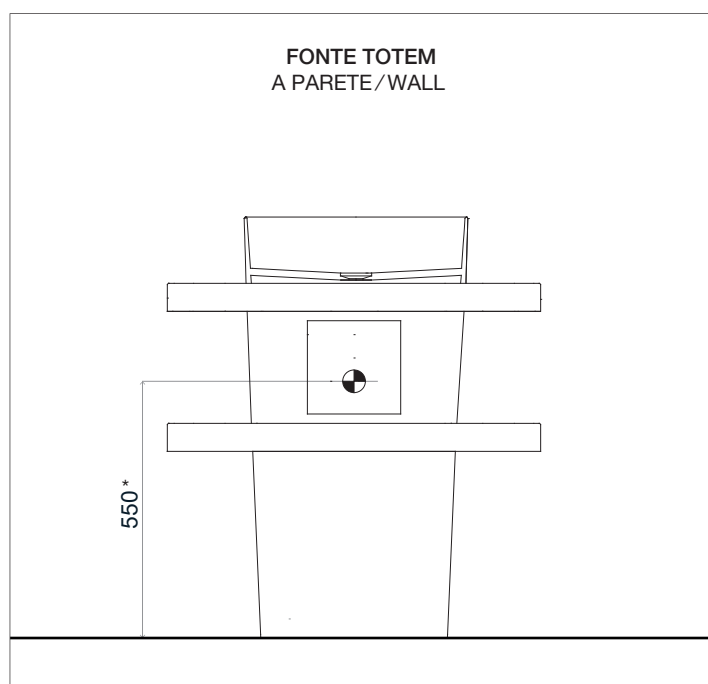
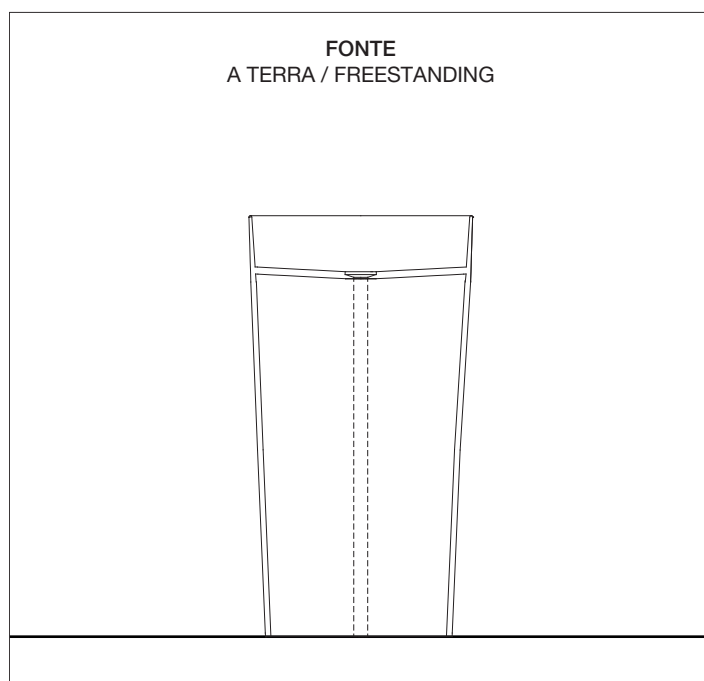
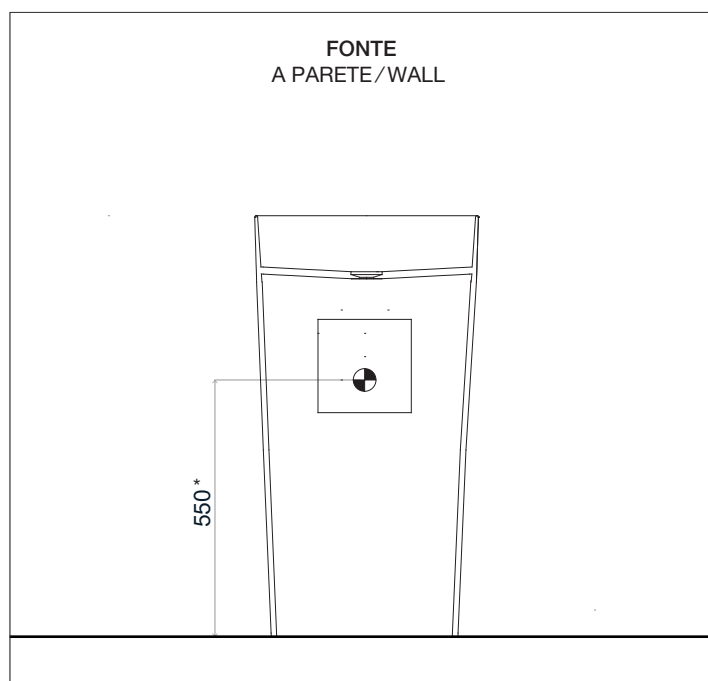

A PARETE/WALL

Non incluso
/Not included

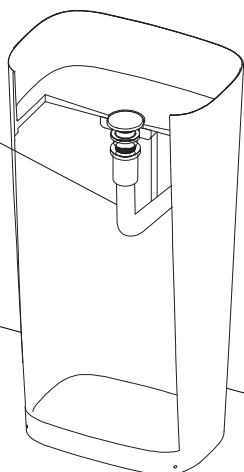

A TERRA / FREESTANDING

Non incluso
/Not included

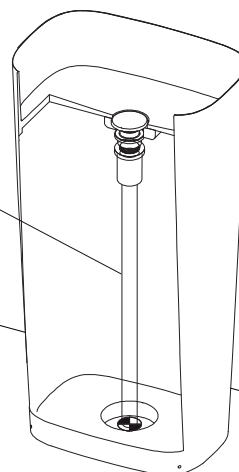

1

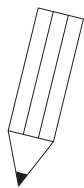

2

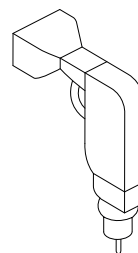

3

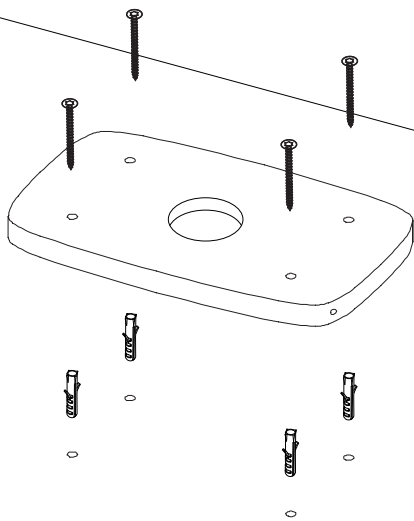

4

Scarico a terra
/Floor drain

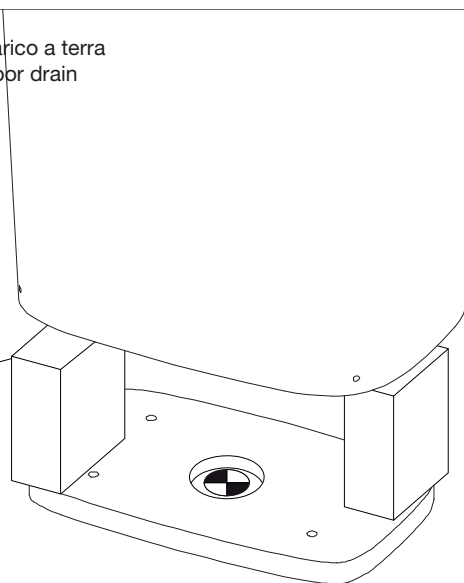

Effettuare collegamento idraulico.
/Make hydraulic connections.

